

ASSEMBLY INSTRUCTION

MODEL: CARLA TABLE

Important note: - Place all wooden part on a clean and smooth surface such as rug or carpet to avoid the part from being scratch.
 - Please follow the assembly instruction step by step.
 - Do not tighten all screw until the table is fully set-up.

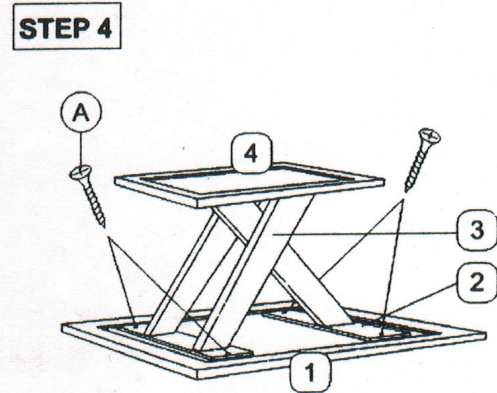
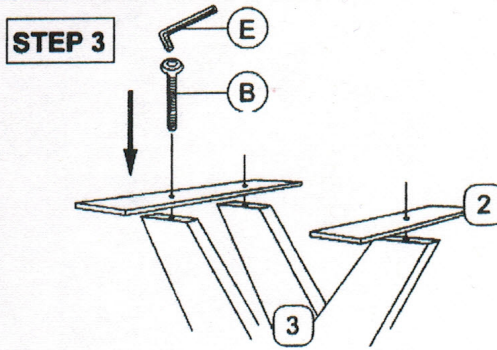
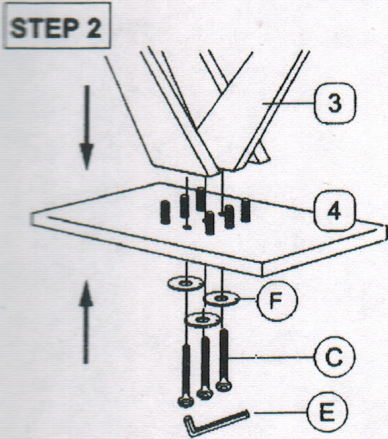
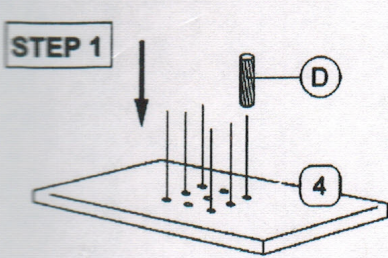

Part List 3pcs

No	DESCRIPTION	QTY.
1	Table Top	3 pc
2	Table Top Support	6 pcs
3	Table Leg	9 pcs
4	Table Bottom	3 pc

Hardware List 3pcs

No	DESCRIPTION	QTY.
A	CSK M4 x 25mm	12 pcs
B	JCBC M6 x 30mm	9 pcs
C	JCBC M6 x 40mm	9 pcs
D	Wood Dowel M8 x 35mm	18 pcs
E	M4 Allen Key	1 pc
F	FLAT WASHER	9 pcs

COMPLETED ASSEMBLE

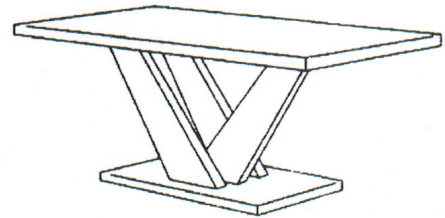

ASSEMBLY INSTRUCTION

MODEL: CARLA TABLE

Important note: - Placez toutes les pieces en bois sure une surface propre et lisse, comme un tapis pour eviter les rayures
 - Suivez les instructions d'assemblage etape par etape
 - Ne pas surrerrer toutes les vis jusqu'a ce que la table est entierement mis en place

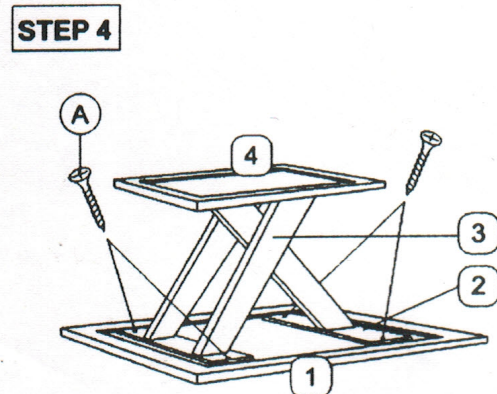
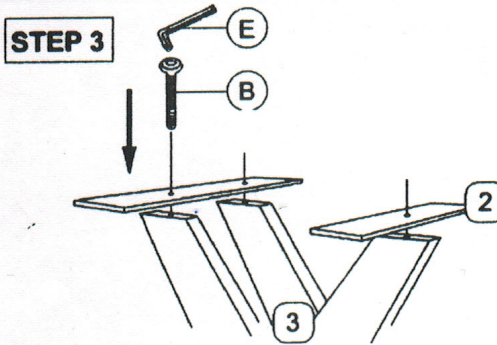
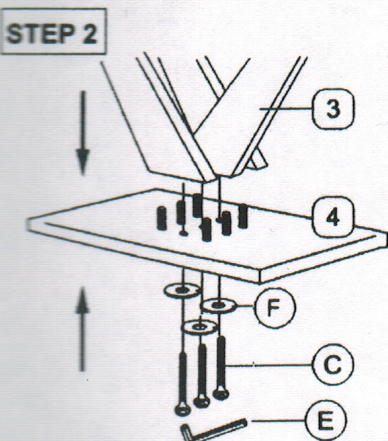
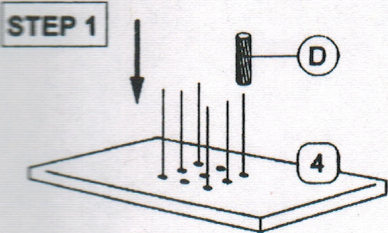

Part List 3pcs

No	DESCRIPTION	QTY.
1	Dessus de la table	3 pc
2	Table support superieur	6 pcs
3	Pied de table	9 pcs
4	Table de fond	3 pc

Hardware List 3pcs

No	DESCRIPTION	QTY.
A	CSK M4 x 25mm	12 pcs
B	JCBC M6 x 30mm	9 pcs
C	JCBC M6 x 40mm	9 pcs
D	Cheville bois M8 x 35mm	18 pcs
E	M4 Cle Allen	1 pc
F	Rondelle Plate	9 pcs

COMPLETED ASSEMBLE

